



# Scripting Languages

Laszlo SZATHMARY  
University of Debrecen  
Faculty of Informatics

## Lab #5

- set
- dictionary

(last update: 2023-02-06 [yyyy-mm-dd])

2022-2023, 2nd semester



# set

<https://docs.python.org/3/library/stdtypes.html#set-types-set-frozenset>

```
>>> basket = ['apple', 'anas', 'banana', 'apple', 'orange', 'banana']
>>> fruits = set(basket)
>>> fruits
set(['orange', 'anas', 'apple', 'banana'])
>>> type(fruits)
<type 'set'>
>>> li = list(fruits)
>>> li
['orange', 'anas', 'apple', 'banana']
>>> type(li)
<type 'list'>
>>> sorted(li)
['anas', 'apple', 'banana', 'orange']
>>> fruits
set(['orange', 'anas', 'apple', 'banana'])
>>> 'kiwi' in fruits
False
>>> 'apple' in fruits
True
```

removing duplicates

Is an element in the set?

## Exercise:

Consider the following elements: [5, 2, 3, 5, 1, 4, -200, 5, 1, 3, 2, 2, 5].  
Remove the duplicates, i.e. one element can be present in the result at most once. The elements in the result should be sorted. ([set01](#))

list to set

```
>>> a = ['apple', 'banana', 'lemon']
>>> a = set(a)
>>> a
set(['lemon', 'apple', 'banana'])
>>> b = set()
>>> b.add('banana')
>>> b.add('orange')
>>> b
set(['orange', 'banana'])
>>> a.union(b)
set(['orange', 'lemon', 'apple', 'banana'])
>>> a.intersection(b)
set(['banana'])
>>> a.difference(b)
set(['lemon', 'apple'])
>>> a
set(['lemon', 'apple', 'banana'])
>>> a.remove('lemon')
>>> a
set(['apple', 'banana'])
```

empty set;  
extending a set

classic  
set operations

removing an element



# dictionary

for storing  
key / value  
pairs

```
1 >>> d = { }
2 >>> d['a'] = 'alfa'
3 >>> d['b'] = 'beta'
4 >>> d['g'] = 'gamma'
5 >>> d
6 {'a': 'alfa', 'b': 'beta', 'g': 'gamma'}
7 >>> d['a']
8 'alfa'
9 >>> d['o']
10 Traceback (most recent call last):
11   File "<stdin>", line 1, in <module>
12   KeyError: 'o'
13 >>> d.get('o')
14 >>> d.get('a')
15 'alfa'
16 >>> 'a' in d
17 True
18 >>> 'o' in d
19 False
20 >>> d['a'] = 'ALFA'
21 >>> d['a']
22 'ALFA'
23 >>> d
24 {'a': 'ALFA', 'b': 'beta', 'g': 'gamma'}
```

empty dictionary  
( or: d = dict() )

Is an element with the  
given key in the dictionary?

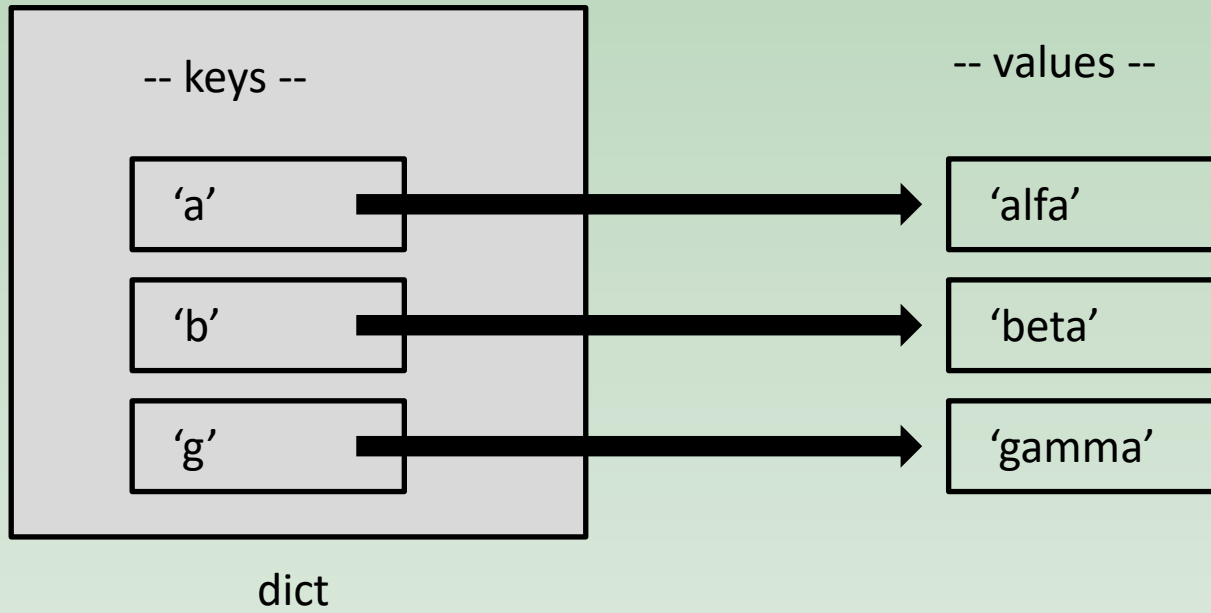

```
>>> d
{'b': 'beta', 'g': 'gamma', 'a': 'alfa'}
>>> d['o'] = 'omega'
>>> d
{'o': 'omega', 'b': 'beta', 'g': 'gamma', 'a': 'alfa'}
>>> d.keys()
dict_keys(['o', 'b', 'g', 'a'])
>>> type(d.keys())
<class 'dict_keys'>
>>> d.values()
dict_values(['omega', 'beta', 'gamma', 'alfa'])
>>> type(d.values())
<class 'dict_values'>
>>> for k in sorted(d.keys()):
...     print("key:", k, "=>", d[k])
...
key: a => alfa
key: b => beta
key: g => gamma
key: o => omega
>>> d.items()
dict_items([('o', 'omega'), ('b', 'beta'), ('g', 'gamma'), ('a', 'alfa')])
>>> type(d.items())
<class 'dict_items'>
>>> for k, v in d.items():
...     print(k, v)
...
o omega
b beta
g gamma
a alfa
>>> list(d.keys())
['o', 'b', 'g', 'a']
```

← the order of the elements is arbitrary

← using iterators in a loop

← Iterator to list. The order is arbitrary.

iterators:  
d.keys()  
d.values()  
d.items()

using iterators in a loop

**HW:** [dict1.py](#)

## removing an element from a dictionary

```
1 >>> a = 6
2 >>> a
3 6
4 >>> del a
5 >>> a
6 Traceback (most recent call last):
7   File "<stdin>", line 1, in <module>
8 NameError: name 'a' is not defined
9 >>>
10 >>> li = range(5)
11 >>> li
12 [0, 1, 2, 3, 4]
13 >>> del li[-1]
14 >>> li
15 [0, 1, 2, 3]
16 >>>
17 >>> d
18 {'a': 'alfa', 'b': 'beta', 'o': 'omega', 'g': 'gamma'}
19 >>> del d['b']
20 >>> d
21 {'a': 'alfa', 'o': 'omega', 'g': 'gamma'}
```





homework

# Exercises

1. [[20120904a](#)] removing duplicates (set)
2. [[20120905a](#)] dictionary #1
3. [[20120921a](#)] accent removal
4. [[20130218b](#)] certain characters
5. [[20120818h](#)] one hundred 50-digit long numbers (PE #13)  
[version **A** only]
6. [[20120816a](#)] 8 queens